



[To visit our website, www.flow.co.za, click here](http://www.flow.co.za)

X-Remote_Contr_Interface_1_070727_25.doc
[E:\DOCUMENTS\Write-Ups_2006\X-WRITE_UPS_AND_PUBLICATIONS_2006_09_M18\X-SCADA-INTERFACE/...]
DATE: 2005-11-24
UPDATE: 2007-07-27

Remote control of FlowSort X-Ray Diamond Recovery machines

Often referred to as the **FlowSort Scada Interface**

1. Introduction

Each Flow Sort Diamond Recovery Machine provides for a remote sorter control.

The purpose of this interface facility is to allow basic sorter operation to be executed from a remote sorter / plant control centre. The interface caters for sorter control inputs as well as for sorter interlock / sorter operation status outputs.

OUTPUTS FROM THE SORTER

Sorter Ready	Indicates that the sorter has 3-phase power and is ready to be switched on.
Sorter On	Indicates that the sorter is switched on.
Feeder Ready (Feeder off)	Indicates that the feeder is off and/or is ready to be turned on.
Feeder On	Indicates that the feeder is running
Size Selection 1, 2 or 3	This output indicates the material size fraction for which the sorter has been set-up (Size 1,2 or 3). Note that for each size selection the appropriate preset values for feed hopper gate height, vibrating feeder amplitude as well as the correct optics sensitivity are automatically selected.
Sorter in Alarm	Indicates if the sorter is in alarm, this will happen no mater the alarm. If an alarm occurs the sorter must be inspected.

INPUTS TO (CONTROL) THE SORTER

Sorter Start / Stop	Allows the sorter/s to be remotely started and stopped.
Feeder Start / Stop	Remotely starting and stopping the sorter's Vibrating Feeder. This is also a useful sorter control input for interlocking with a feed bin level probes ensuring that the sorter does not “batch feed”, interlocking with a tailings feeder, tailings conveyor, etc..
Size Selection	Any one of three preset sorter feed-size set-ups can be selected from a remote control facility. Such selection can also be linked to automatically opening the storage bin containing the appropriate ore size fraction etc.
Alarm Reset	Allows to clear a sorter alarm from a remote sorter control facility. Note however, that whenever a sorter goes into alarm mode it is necessary to establish what caused the problem rather than just resetting the alarm! A Flow Sort Monitoring System will allow for proper remote fault analyses often avoiding the need to send a technician to physically attend to the sorter. Refer to the write-up entitled: “Why you should link your Flow Sort Diamond Recovery Machines to a Flow Sort Computer Monitoring System? (X-MONITOR_GENERAL_M11.DOC).

2. Interface Connections

The Interface Points consists of one Male and one Female 19-way Souriau connector, which are located on the bottom right-hand side of the control panel.

2.1 Inputs

A 19 way ‘**female**’ Souriau connector, at the sorters control panel, provides for control Inputs. A matching 19 way male Souriau connector is supplied with the sorter.

All inputs are connected to relay-coils (2880 Ohms). These relay coils are in turn connected to the + (positive) terminal of the sorter’s-internal 24 Volt dc power supply. EMF absorption diodes are fitted across all relay coils.

Inputs must be activated / de-activated via remote POTENTIAL-FREE CONTACTS which must be connected (common) to the – (negative) terminal of the sorter’s internal 24 Volt power supply which is accessible via interface connection point **Pin 110** of the Souriau connector. (Refer to drawing: **X-Scada_IF04_INputs_M16.Sch**).

The remote control contact rating must be at least 48 Volt 100 mA d.c.

The following table lists the available inputs:

For ease of identification you find the Input (To Sorter) Connections labelled from 101 – 111. (101 is pin 1 on Souriau, 102 is pin 2, 103 is).

SORTER CONTROL INPUTS			
	Function	Signal From Remote Control	Input Pins on Souriau Connector
1	Start-up Sorter	Impulse, remote control contact must close for between 0.3 and 1 second.	Impulse closed contact between pin 102 and 110 (common)
2	Shut-down Sorter	Impulse, remote control contact must close for between 0.3 and 1 second.	Impulse closed contact between pin 103 and 110 (common)
3	Switch-on Feeder	Impulse, remote control contact must close for between 0.3 and 1 second.	Impulse closed contact between pin 104 and 110 (common)
4	Switch-off Feeder	Impulse, remote control contact must close for between 0.3 and 1 second.	Impulse closed contact between pin 105 and 110 (common)
5	Reset Sorter Alarm	Impulse, remote control contact must close for between 0.3 and 1 second.	Impulse closed contact between pin 106 and 110 (common)
6	Local Size Select (If activated size-selection cannot be selected on Control Panel)	Continues, remote control contact must be closed continuously	Continues closed contact between pin 111 and 110
7.	Size Selection NB Only one of the following to be active at any given time		
7.1	Size 1	Continues, remote control contact must be closed continuously	Continues closed contact between pin 107 and 110
7.2	Size 2	Continues, remote control contact must be closed continuously	Continues closed contact between pin 108 and 110
7.3	Size 3	Continues, remote control contact must be closed continuously	Continues closed contact between pin 109 and 110

2.2 Outputs

A 19 way **male-Souriau** connector at the sorters control panel provides for (the more important) sorter operating status **Outputs**.

(Flow Sort supplies a 19-way female, cable mount, Souriau connector from connecting to this point)

All outputs are connected via Normally Open dry relays contacts with a maximum rating of 48V 100 mA d.c.

Output contacts, except for “Sorter Ready” are connected to a POTENTIAL FREE COMMON connection point. 1. (Refer to drawing: **X-Scada_IF04_OUTputs_M16.Sch**)

The following table lists the available outputs:

For ease of identification you find the Output (From Sorter) Connections labelled from 1 – 11, directly corresponding to the Souriau connector pin numbers (1 is pin 1 on Souriau, 2 is pin 2, 3 is).

OUTPUT INDICATIONS/INTERLOCKS			
	Indication	Description	Output Pins on Souriau Connector
1	Sorter Ready	Power on Sorter, Sorter is ready to be switched on.	Closed contact between pin 9 and 10
2	Sorter ON	Sorter is switched On.	Closed contact between pin 2 and 1 (common)
3	Feeder Ready	Feeder is ready to be switched on.	Closed contact between pin 8 and 1 (common)
4	Feeder ON	Feeder is switched On	Closed contact between pin 3 and 1 (common)
5	Alarm ON	Sorter is in Alarm	Closed contact between pin 4 and 1 (common)
6.	Size Selection NB Only one of the following outputs will be active at any given time		
6.1	Size 1 Selected	Sorter set-up for ore size 1 is selected	Closed contact between pin 5 and 10
6.2	Size 2 Selected	Sorter set-up for ore size 2 is selected	Closed contact between pin 6 and 10
6.3	Size 3 Selected	Sorter set-up for ore size 3 is selected	Closed contact between pin 7 and 10

3. TIMING REQUIREMENTS

The following table depicts a typical operating sequence.

For ease of reference the input connections (To Sorter) are labelled from 101 – 111. (101 is pin 1 on Souriau, 102 is pin 2 etc.), and the output connections (From Sorter) are labelled directly according to the Souriau Connector pin numbers (1 is pin 1 on Souriau, 2 is pin 2 on Souriau).

TYPICAL SORTER START-UP SEQUENCE			
	Action	Interface condition	Possible cause of missing / required condition
1.	Verify that “Sorter Ready” is active	Sorter contact between PIN 9 and 10 is closed. This condition must be static for at least 30 min before proceeding to “Start sorter”!	No power at sorter, sorters Isolator switch is off etc.
2.	Start Sorter	Close contact between pin 102 and 110 for between 0.3 and 1.0 sec.	
3.	WAIT for at least 1 second		
4.	Verify that “Sorter ON” is active	Sorter closes contact between pin 1 and 2	Sorter “STOP” active. (Either on Control Panel or on remote control)
5.	WAIT for at least 1 second		
6.	Select a preset material Size set-up IMPORTANT: Only on size selection is allowed to be active at any given time!	The contact for the relevant size selection must remain closed until another preset size is to be selected.	
	Select Material Size Pre-Setting 1	Close contact between pin 107 and 110 and keep closed until another size pre-setting is selected	
	Select Material Size Pre-Setting 2	Close contact between pin 108 and 110 and keep it closed until another size presetting is to be selected.	
	Select Material Size Pre-Setting 3	Close contact between pin 109 and 110 and keep it closed until another pre-setting is to be selected.	
7.	Wait for at least 1 second		

8.	Verify that Size Selection is correct. Only one size selection can be active at any given time!		If none of the 3 possible size selection outputs are active (contact closed) it indicates that the Sorter is not in full operation!
8.1	Size 1	Sorter closes contact between PIN 1 and 5	
8.2	Size 2	Sorter closes contact between PIN 1 and 6	
8.3	Size 3	Sorter closes contact between PIN 1 and 7	
10.	Wait for at least 60 seconds for the Sorter start-up sequence to be completed.		
6.	Verify that “Feeder Ready” is active	When the sorter is fully operational the contact between PIN 1 and 8 is closed.	1. Sorter in Alarm 2. Feeder STOP active on remote control
7.	Start Feeder	Close contact between pin 104 and 110 for between 0.3 and 1.0 sec.	
8.	Wait for at least 15 sec to allow the sorters automatic self-test to complete.		
9.	Verify Feeder is on	Sorter closes contact between PIN 1 and 3 when the feeder is running. NOTE: The sorter automatically opens this contact for approx. 15 sec every time the sorter performs an auto-test cycle.	1. Sorter is in Alarm 2. Autotest cycle active. 3. Sorter failed Autotest
TYPICAL SORTER SHUT-DOWN SEQUENCE			
10.	Stop Feeder	Close contact between pin 105 and 110 for between 0.3 and 1.0 sec.	
11.	Wait for at least 1 sec		
12.	Verify that “Feeder Ready” is active	Sorter contact between PIN 1 and 8 is closed.	
13.	Stop Sorter	Close contact between pin 103 and 110 for between 1.0 and 2.0 sec.	
14.	Wait for at least 1 second		
14.	Verify Sorter is off	Sorter opens contact between PIN 1 and 2	

4. AUTOTEST SEQUENCE

The sorter automatically performs a self-test (“Autotest”) at the following times:

- a. After every a Vibrating feeder switch-on
- b. When changing the pre-select material size setting whilst the feeder is running.
- c. After every 20 minutes of continuous feeder running time.

The following illustrates a typical “auto-test” sequence:

1. “Feeder On” contact closes for approx. 2 sec.
2. “Feeder On” contact opens
3. “Feeder Ready” contact closes.

The sorter performs an Auto-test which takes +- 15 sec.

4. If the sorter passed the Auto-test the “Feeder-On” contact closes and the “Feeder-Ready” contact opens.
5. If the sorter fails the Auto-test, the “Feeder Ready” ready contact opens and the “Alarm” contact closes

5. HARDWARE REQUIREMENTS

1. 1 x 19-way female, cable-mount, Souriau connector. Supplied by Flow Sort with the sorter’s commissioning kit.
2. 1 x 19-way male, cable-mount, Souriau connector. Supplied by Flow Sort with the sorter’s commissioning kit.
3. 1 x 12 core cable with a conductor size not exceeding 0.5mm for inputs to the Sorter from the remote control facility.
4. 1 x 12 core cable with a conductor size not exceeding 0.5mm for outputs from Sorter to the remote control facility

Note: Both 19-way Souriau connector cable mount shells accept cables with a maximum outside diameter of 16mm. The connectors must be soldered to their respective cables.

Flow Sort strongly recommends that soldering these connectors onto the interface cables to be done by a suitably skilled and qualified person.

To make site installation work simple and efficient, Flow Sort offers to supply, as an optional extra the following:

Option 1:

1. 1 x 19-way female Souriau connector, pre-fitted to a labelled multi-core cable (of customer specified length).
2. 1 x 19-way male Souriau connector, pre-fitted to labelled multi-core cable (of customer specified length).

Option 2:

1. 1 x 19-way female Souriau connector fitted to labelled multi-core cable.
2. 1 x 19-way male Souriau connector fitted to labelled multi-core cable.
3. 1 x “interconnection” box (300mm x 200mm x 120mm) fitted with cable compression glands as per customer specification and with numbered screw-terminals which allows joining up with the relevant, customer supplied cable.
 - i. The position of such an “interconnection box” must be specified by the customer.

PLEASE DISCUSS ALL YOUR FLOW SORT X-RAY DIAMOND RECOVERY REMOTE CONTROL REQUIREMENTS **BEFORE** DESIGNING YOUR PLANT CONTROL SYSTEM!
ALL OUR EXPERTISE AND EXPERIENCE IS AT YOUR SERVICE!

SEE
PC125C_SCH_02.Sch
FOR COMPLETE
CIRCUIT

SORTER INPUTS

SORTER CONTROL PANEL

FEMALE SOURIAU CONNECTOR

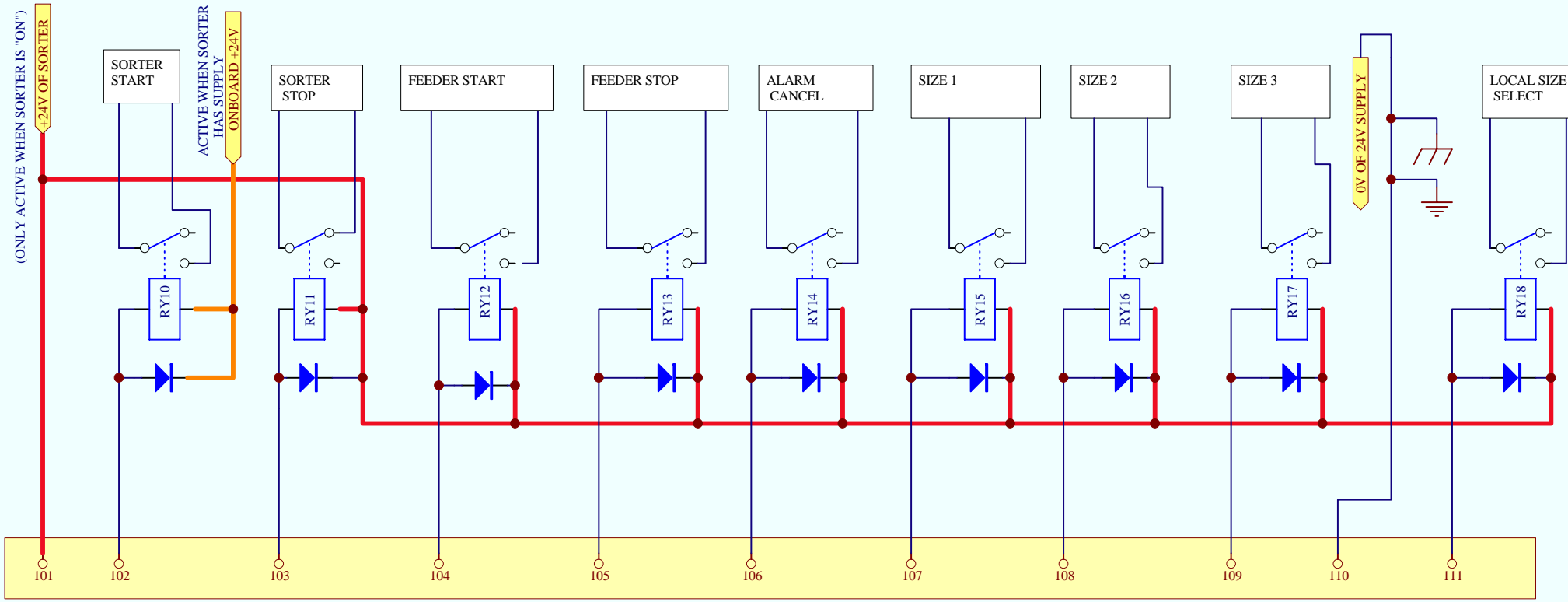

MALE SOURIAU CONNECTOR

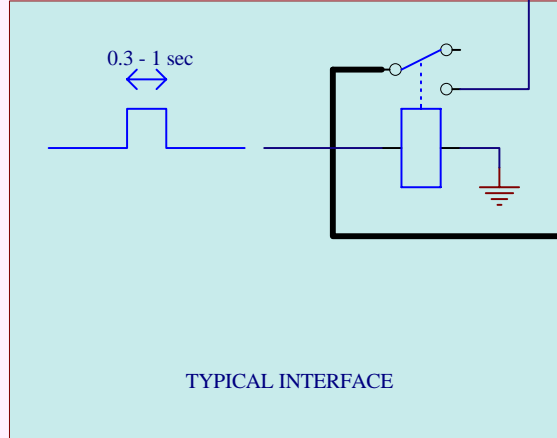
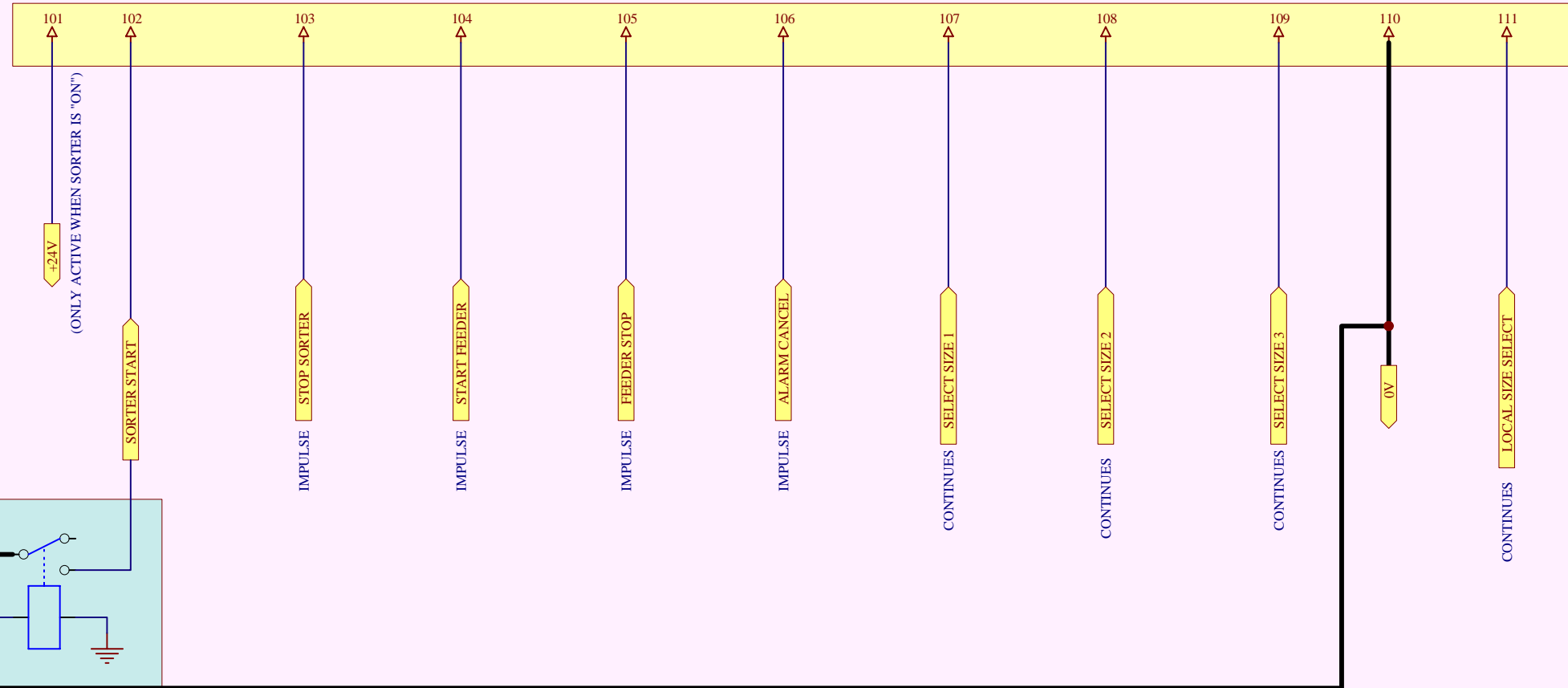

TYPICAL INTERFACE

REMOTE CONTROL UNIT



OUTPUTS TO PLC/SCADA

- COMMON
- SORTER ON
- FEEDER ON
- ALARM ON
- SIZE 1 SELECTED
- SIZE 2 SELECTED
- SIZE 3 SELECTED
- FEEDER READY
- SORTER READY
- SORTER READY
- 0V
- RS422 +TX
- RS422 -TX
- RS422 +RX
- RS422 -RX
- SIZE 4 SELECTED

INPUTS FROM PLC/SCADA

- +24V
- SORTER START
- SORTER STOP
- START FEEDER
- STOP FEEDER
- ALARM CANCEL
- SELECT SIZE 1
- SELECT SIZE 2
- SELECT SIZE 3
- 0V
- LOCAL SIZE SELECT
- SELECT SIZE 4

MODIFICATION IN CONTROL PANEL

TO S4 ON SELECTOR SWITCH

24V RELAY

112 BLUE

16 PURPLE

16 RED/BLACK

101 RED

1 GREEN

110 BLUE

S4 ORANGE

S4 ORANGE

FEMALE SOURIAU CONNECTOR

19 18 17 16 15 14 13 12 11 10 9 8 7 6 5 4 3 2 1

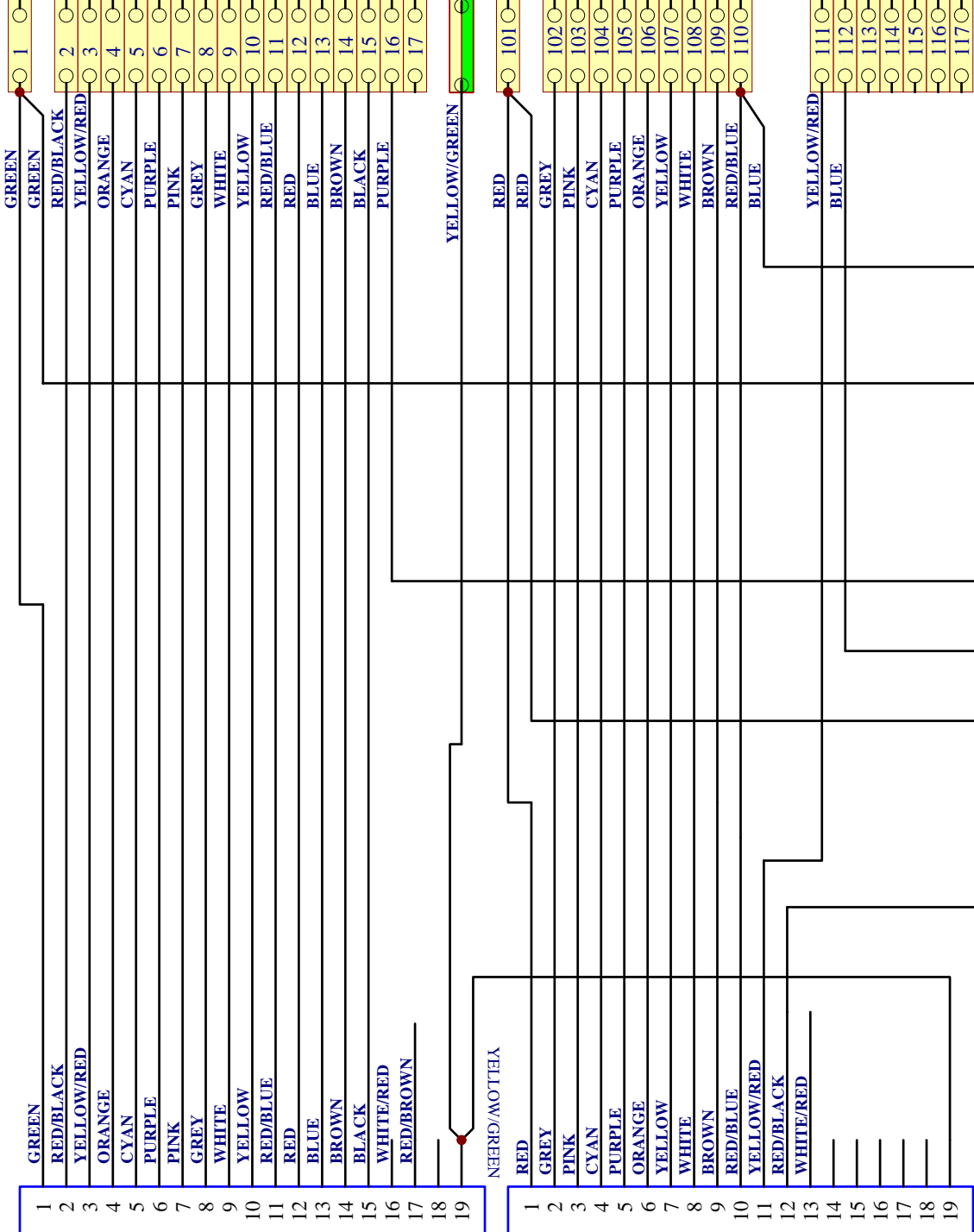

SEE
PC125C_SCH_02.Sch
FOR COMPLETE
CIRCUIT

SORTER OUTPUTS

MALE SOURIAU
CONNECTOR

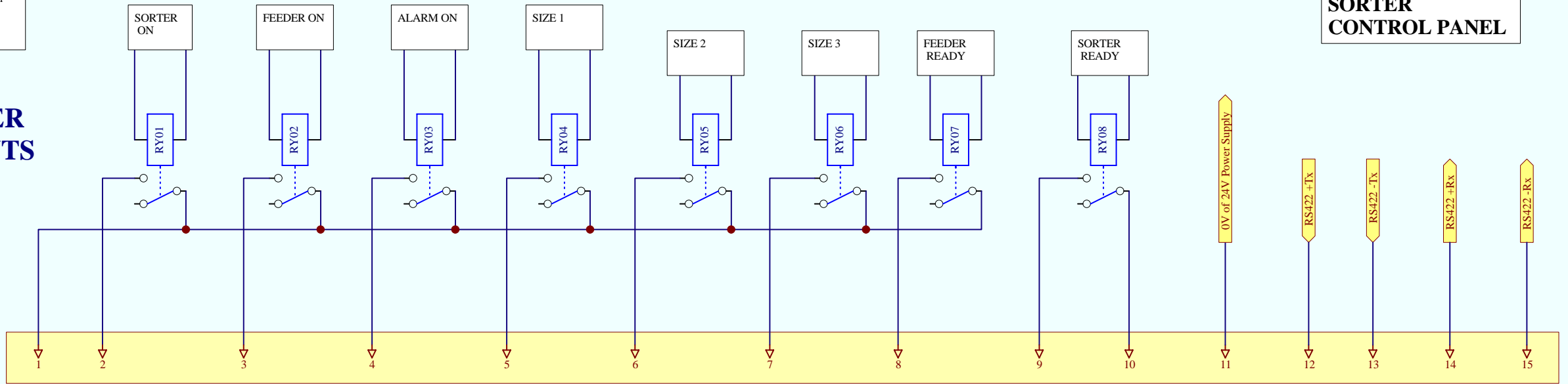

SORTER CONTROL PANEL

FEMALE SOURIAU
CONNECTOR

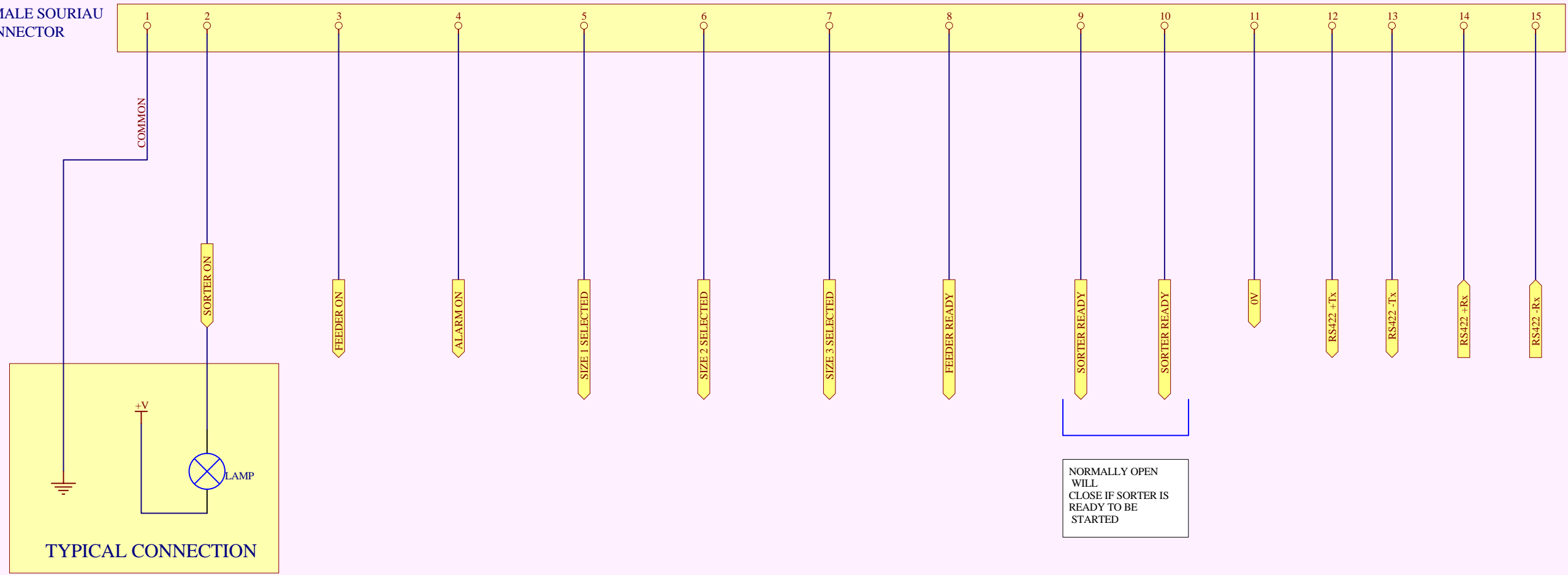

TYPICAL CONNECTION

NORMALLY OPEN
WILL
CLOSE IF SORTER IS
READY TO BE
STARTED

REMOTE CONTROL UNIT

